



Standard Test Method for Electronic Friction Cone and Piezocone Penetration Testing of Soils¹

This standard is issued under the fixed designation D5778; the number immediately following the designation indicates the year of original adoption or, in the case of revision, the year of last revision. A number in parentheses indicates the year of last reapproval. A superscript epsilon (ϵ) indicates an editorial change since the last revision or reapproval.

1. Scope*

1.1 This test method covers the procedure for determining the point resistance during penetration of a conical-shaped penetrometer as it is advanced into subsurface soils at a steady rate.

1.2 This test method is also used to determine the frictional resistance of a cylindrical sleeve located behind the conical point as it is advanced through subsurface soils at a steady rate.

1.3 This test method applies to friction-cone penetrometers of the electric and electronic type. Field tests using mechanical-type penetrometers are covered elsewhere by Test Method [D3441](#).

1.4 This test method can be used to determine porewater pressures developed during the penetration, thus termed piezocone. Porewater pressure dissipation, after a push, can also be monitored for correlation to time rate of consolidation and permeability.

1.5 Additional sensors, such as inclinometer, seismic geophones (Test Methods [D7400](#)), resistivity, electrical conductivity, dielectric, and temperature sensors, may be included in the penetrometer to provide useful information. The use of an inclinometer is highly recommended since it will provide information on potentially damaging situations during the sounding process.

1.6 Cone penetration test data can be used to interpret subsurface stratigraphy, and through use of site specific correlations, they can provide data on engineering properties of soils intended for use in design and construction of earthworks and foundations for structures.

1.7 The values stated in SI units are to be regarded as standard. Within Section 13 on Calculations, SI units are considered the standard. Other commonly used units such as the inch-pound system are shown in brackets. The various data reported should be displayed in mutually compatible units as

agreed to by the client or user. Cone tip projected area is commonly referred to in square centimetres for convenience. The values stated in each system are not equivalents; therefore, each system shall be used independently of the other.

NOTE 1—This test method does not include hydraulic or pneumatic penetrometers. However, many of the procedural requirements herein could apply to those penetrometers. Also, offshore/marine CPT systems may have procedural differences because of the difficulties of testing in those environments (for example, tidal variations, salt water, waves). Mechanical CPT systems are covered under Test Method [D3441](#).

1.8 *This standard does not purport to address all of the safety concerns, if any, associated with its use. It is the responsibility of the user of this standard to establish appropriate safety and health practices and determine the applicability of regulatory limitations prior to use.*

2. Referenced Documents

2.1 *ASTM Standards:*²

[D653 Terminology Relating to Soil, Rock, and Contained Fluids](#)

[D3441 Test Method for Mechanical Cone Penetration Tests of Soil \(Withdrawn 2014\)](#)³

[D3740 Practice for Minimum Requirements for Agencies Engaged in Testing and/or Inspection of Soil and Rock as Used in Engineering Design and Construction](#)

[D7400 Test Methods for Downhole Seismic Testing](#)

[E4 Practices for Force Verification of Testing Machines](#)

3. Terminology

3.1 *Definitions:*

3.1.1 Definitions are in accordance with Terminology Convention ([D653](#)).

3.2 *Definitions of Terms Specific to This Standard:*

3.2.1 *apparent load transfer*—apparent resistance measured on either the cone or friction sleeve of an electronic cone penetrometer while that element is in a no-load condition but

¹ This test method is under the jurisdiction of ASTM Committee [D18](#) on Soil and Rock and is the direct responsibility of Subcommittee [D18.02](#) on Sampling and Related Field Testing for Soil Evaluations.

Current edition approved Jan. 1, 2012. Published February 2012. Originally approved in 1995. Last previous edition approved in 2007 as [D5778-07](#). DOI: 10.1520/D5778-12.

² For referenced ASTM standards, visit the ASTM website, www.astm.org, or contact ASTM Customer Service at service@astm.org. For *Annual Book of ASTM Standards* volume information, refer to the standard's Document Summary page on the ASTM website.

³ The last approved version of this historical standard is referenced on www.astm.org.

*A Summary of Changes section appears at the end of this standard

the other element is loaded. Apparent load transfer is the sum of cross talk, subtraction error, and mechanical load transfer.

3.2.2 *baseline*—a set of zero load readings, expressed in terms of apparent resistance, that are used as reference values during performance of testing and calibration.

3.2.3 *cone tip*—the conical point of a cone penetrometer on which the end bearing component of penetration resistance is developed. The cone has a 60° apex angle, a diameter of 35.7 mm, and a corresponding projected (horizontal plane) surface area or cone base area of 10 cm². Also, enlarged cones of 43.7 mm diameter (base area = 15 cm²) are utilized.

3.2.4 *cone penetration test*—a series of penetration readings performed at one location over the entire vertical depth when using a cone penetrometer. Also referred to as a cone sounding.

3.2.5 *cone penetrometer*—a penetrometer in which the leading end of the penetrometer tip is a conical point designed for penetrating soil and for measuring the end-bearing component of penetration resistance.

3.2.6 *cone resistance, q_c* —the measured end-bearing component of penetration resistance. The resistance to penetration developed on the cone is equal to the vertical force applied to the cone divided by the cone base area.

3.2.7 *corrected total cone resistance, q_t* —tip resistance corrected for water pressure acting behind the tip (see 13.2.1). Correction for water pressure requires measuring water pressures with a piezocone element positioned behind the tip at location u_2 (See section 3.2.26). The correction results in estimated total tip resistance, q_t .

3.2.8 *cross talk*—an apparent load transfer between the cone and the friction sleeve caused by interference between the separate signal channels.

3.2.9 *electronic cone penetrometer*—a friction cone penetrometer that uses force transducers, such as strain gauge load cells, built into a non-telescoping penetrometer tip for measuring, within the penetrometer tip, the components of penetration resistance.

3.2.10 *electronic piezocone penetrometer*—an electronic cone penetrometer equipped with a low volume fluid chamber, porous element, and pressure transducer for determination of porewater pressure at the porous element soil interface measured simultaneously with end bearing and frictional components of penetration resistance.

3.2.11 *end bearing resistance*—same as cone resistance or tip resistance, q_c .

3.2.12 *equilibrium pore water pressure, u_0* —at rest water pressure at depth of interest.

3.2.13 *excess pore water pressure, Δu* —the difference between porewater pressure measured as the penetration occurs (u), and estimated equilibrium porewater pressure (u_0), or: $\Delta u = (u - u_0)$. Excess porewater pressure can either be positive or negative for shoulder position filters.

3.2.14 *friction cone penetrometer*—a cone penetrometer with the capability of measuring the friction component of penetration resistance.

3.2.15 *friction ratio, R_f* —the ratio of friction sleeve resistance, f_s , to cone resistance, q_c , measured at where the middle of the friction sleeve and cone point are at the same depth, expressed as a percentage.

NOTE 2—Some methods to interpret CPT data use friction ratio defined as the ratio of sleeve friction, f_s , to cone resistance corrected for pore pressure effects q_t , (1). It is not within the scope of this standard to recommend which methods of interpretation are to be used.

3.2.16 *friction reducer*—a narrow local protuberance on the outside of the push rod surface, placed at a certain distance above the penetrometer tip, that is provided to reduce the total side friction on the push rods and allow for greater penetration depths for a given push capacity.

3.2.17 *friction sleeve*—an isolated cylindrical sleeve section on a penetrometer tip upon which the friction component of penetration resistance develops. The friction sleeve has a surface area of 150 cm² for 10-cm² cone tips or 225 cm² for 15-cm² tips.

3.2.18 *friction sleeve resistance, f_s* —the friction component of penetration resistance developed on a friction sleeve, equal to the shear force applied to the friction sleeve divided by its surface area.

3.2.19 *FSO*—abbreviation for full-scale output. The output of an electronic force transducer when loaded to 100 % rated capacity.

3.2.20 *local side friction*—same as friction sleeve resistance, f_s (see 3.2.18).

3.2.21 *penetration resistance measuring system*—a measuring system that provides the means for transmitting information from the penetrometer tip and displaying the data at the surface where it can be seen or recorded.

3.2.22 *penetrometer*—an apparatus consisting of a series of cylindrical push rods with a terminal body (end section), called the penetrometer tip, and measuring devices for determination of the components of penetration resistance.

3.2.23 *penetrometer tip*—the terminal body (end section) of the penetrometer which contains the active elements that sense the components of penetration resistance. The penetrometer tip may include additional electronic instrumentation for signal conditioning and amplification.

3.2.24 *piezocone*—same as *electronic piezocone penetrometer* (see 3.2.10).

3.2.25 *piezocone porewater pressure, u* —fluid pressure measured using the piezocone penetration test.

3.2.26 *piezocone porewater pressure measurement location: u_1, u_2, u_3* —fluid pressure measured by the piezocone penetrometer at specific locations on the penetrometer as follows (2, 3, 4)⁴: u_1 —porous filter location on the midface or tip of the cone, u_2 —porous filter location at the shoulder position behind the cone tip (standard location) and, u_3 —porous filter location behind the friction sleeve.

3.2.27 *porewater pressure*—total porewater pressure magnitude measured during penetration (same as 3.2.25 above).

⁴ The boldface numbers given in parentheses refer to a list of references at the end of the text.

3.2.28 *porewater pressure ratio parameter, B_q* —the ratio of excess porewater pressure at the standard measurement location Δu_2 , to corrected total cone resistance q_c , minus the total vertical overburden stress, σ_{vo} (see Eq 10).

3.2.29 *push rods*—the thick-walled tubes or rods used to advance the penetrometer tip.

3.2.30 *sleeve friction, sleeve, and friction resistance*—same as friction sleeve resistance.

3.2.31 *subtraction error*—an apparent load transfer from the cone to the friction sleeve of a subtraction type electronic cone penetrometer caused by minor voltage differences in response to load between the two strain element cells.

3.3 Abbreviations:

3.3.1 *CPT*—abbreviation for the cone penetration test.

3.3.2 *PCPT (2, 3) or CPTu (4)*—abbreviation for piezocone penetration test (note: symbol “u” added for porewater pressure measurements).

3.3.3 *CPTu*—abbreviation for the piezocone penetration test with dissipation phases of porewater pressures (\dot{u}).

3.3.4 *SCPTu*—abbreviation for seismic piezocone test Test Methods D7400 (includes one or more geophones to allow downhole geophysical wave velocity measurements).

3.3.5 *RCPTu*—abbreviation for resistivity piezocone (includes electrical conductivity or resistivity module).

4. Summary of Test Method

4.1 A penetrometer tip with a conical point having a 60° apex angle and a cone base area of 10 or 15 cm² is advanced through the soil at a constant rate of 20 mm/s. The force on the conical point (cone) required to penetrate the soil is measured by electrical methods, at a minimum of every 50 mm of penetration. Improved resolution may often be obtained at 20- or 10-mm interval readings. Stress is calculated by dividing the measured force (total cone force) by the cone base area to obtain cone resistance, q_c .

4.2 A friction sleeve is present on the penetrometer immediately behind the cone tip, and the force exerted on the friction sleeve is measured by electrical methods at a minimum of every 50 mm of penetration. Stress is calculated by dividing the measured axial force by the surface area of the friction sleeve to determine sleeve resistance, f_s .

4.3 Most modern penetrometers are capable of registering pore water pressure induced during advancement of the penetrometer tip using an electronic pressure transducer. These penetrometers are called “piezocones.” The piezocone is advanced at a rate of 20 mm/s, and readings are taken at a minimum of every 50 mm of penetration. The dissipation of either positive or negative excess porewater pressure can be monitored by stopping penetration, unloading the push rod, and recording porewater pressure as a function of time. When porewater pressure becomes constant it is measuring the equilibrium value (designated u_0) or piezometric level at that depth.

5. Significance and Use

5.1 Tests performed using this test method provide a detailed record of cone resistance which is useful for evaluation of site stratigraphy, homogeneity and depth to firm layers, voids or cavities, and other discontinuities. The use of a friction sleeve and porewater pressure element can provide an estimate of soil classification, and correlations with engineering properties of soils. When properly performed at suitable sites, the test provides a rapid means for determining subsurface conditions.

5.2 This test method provides data used for estimating engineering properties of soil intended to help with the design and construction of earthworks, the foundations for structures, and the behavior of soils under static and dynamic loads.

5.3 This method tests the soil in-situ and soil samples are not obtained. The interpretation of the results from this test method provides estimates of the types of soil penetrated. Engineers may obtain soil samples from parallel borings for correlation purposes but prior information or experience may preclude the need for borings.

NOTE 3—The quality of the results produced by this standard is dependent on the competence of the personal performing the test, and the suitability of the equipment and facilities used. Agencies that meet the criteria of Practice D3740 are generally considered capable of competent and objective testing/sampling/inspection/etc. Users of this standard are cautioned that compliance with Practice D3740 does not in itself assure reliable results. Reliable results depend on many factors and Practice D3740 provides a means of evaluating some of those factors.

6. Interferences

6.1 Refusal, deflection, or damage to the penetrometer may occur in coarse grained soil deposits with maximum particle sizes that approach or exceed the diameter of the cone.

6.2 Partially lithified and lithified deposits may cause refusal, deflection, or damage to the penetrometer.

6.3 Standard push rods can be damaged or broken under extreme loadings. The amount of force that push rods are able to sustain is a function of the unrestrained length of the rods and the weak links in the push rod-penetrometer tip string such as push rod joints and push rod-penetrometer tip connections. The force at which rods may break is a function of the equipment configuration and ground conditions during penetration. Excessive rod deflection is the most common cause for rod breakage.

7. Apparatus

7.1 *Friction Cone Penetrometer*—The penetrometer tip should meet requirements as given below and in 10.1. In a conventional friction-type cone penetrometer, the forces at the cone tip and friction sleeve are measured by two load cells within the penetrometer. Either independent load cells or subtraction-type penetrometers are acceptable for use (Fig. 1).

7.1.1 In the subtraction-type penetrometer, the cone and sleeve both produce compressive forces on the load cells. The load cells are joined together in such a manner that the cell nearest the cone (the “C” cell in Fig. 1b) measures the compressive force on the cone while the second cell (the “C + S” cell in Fig. 1b) measures the sum of the compressive

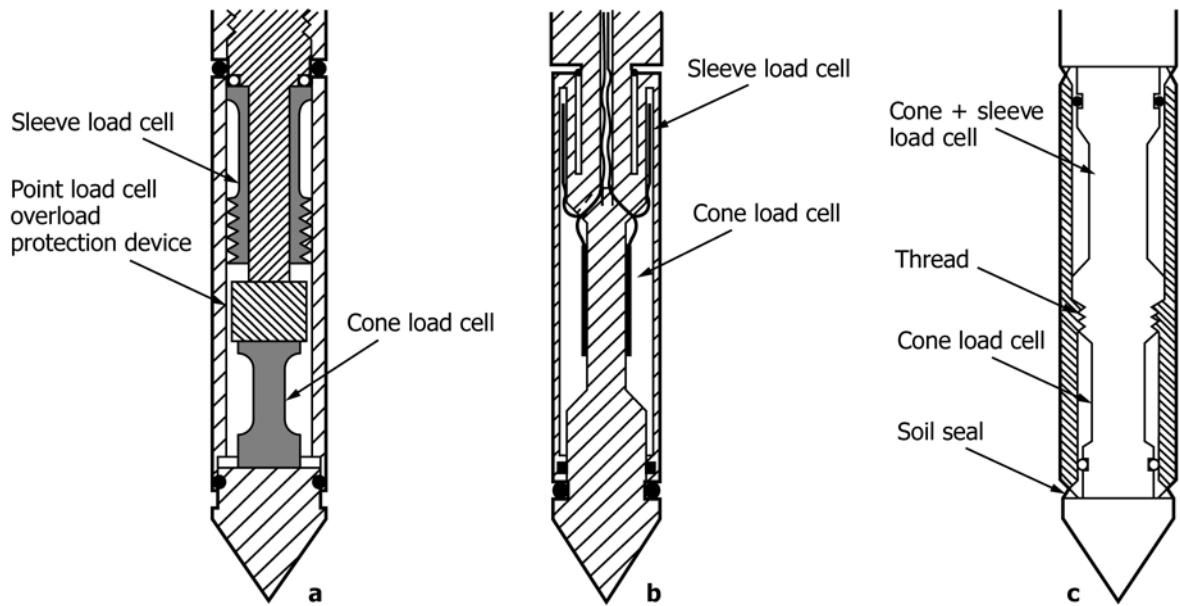

FIG. 1 Common Configurations for Electric Friction-Cone Penetrometers (1) Showing: (a) Compression-type Tip and Sleeve Load Cells, (b) Tension-type Sleeve Design, and (c) Subtraction-type Penetrometer

forces on both the cone and friction sleeve. The compressive force from the friction sleeve portion is computed then by subtraction. This cone design is common in industry because of its rugged design. This design forms the basis for minimum performance requirements for electronic penetrometers.

7.1.1.1 Alternative designs have separate and non-dependent load cells separate for tip and sleeve. For instance, in Fig. 1a, the cone penetrometer tip produces a compression force on the cone load cell (the “C” cell in Fig. 1a) while the friction sleeve produces a tensile force on the independent friction sleeve load cell (the “S” cell). Designs are also available where both the tip and sleeve load cells are independent and operate in compression (1). These penetrometer designs result in a higher degree of accuracy in friction sleeve measurement, however, may be more susceptible to damage under extreme loading conditions.

7.1.1.2 Typical general purpose cone penetrometers are manufactured to full scale outputs (FSO) equivalent to net loads of 10 to 20 tons. Often, weak soils are the most critical in an investigation program, and in some cases, very accurate friction sleeve data may be required. To gain better resolution, the FSO can be lowered or the independent type penetrometer design can be selected. A low FSO subtraction cone may provide more accurate data than a standard FSO independent type cone depending on such factors as system design and thermal compensation. If the FSO is lowered, this may place electrical components at risk if overloaded in stronger soils. Expensive preboring efforts may be required to avoid damage in these cases. The selection of penetrometer type and resolution should consider such factors as practicality, availability, calibration requirements, cost, risk of damage, and preboring requirements.

7.1.1.3 The user or client should select the cone design requirements by consulting with experienced users or manu-

facturers. The need for a specific cone design depends on the design data requirements outlined in the exploration program.

7.1.1.4 Regardless of penetrometer type, the friction sleeve load cell system must operate in such a way that the system is sensitive to only shear stresses applied to the friction sleeve and not to normal stresses.

7.1.2 Cone—Nominal dimensions, with manufacturing and operating tolerances, for the cone are shown on Fig. 2. The cone has a diameter $d = 35.7$ mm, projected base area $A_c = 1000$ mm², + 2%–5% with an apex angle of 60°. A cylindrical extension, h_e , of 5 mm should be located behind the base of the cone to protect the outer edges of the cone base from excessive wear. The 10 cm² cone is considered the reference standard for which results of other penetrometers with proportionally scaled dimensions can be compared.

7.1.2.1 In certain cases, it may be desirable to increase the cone diameter in order to add room for sensors or increase ruggedness of the penetrometer. The standard increase is to a base diameter of 43.7 mm which provides a projected cone base area of 1500 mm² while maintaining a 60° apex angle. Nominal dimensions, with manufacturing and operating tolerances for the 15 cm² cone, are shown in Fig. 2, based on the international guides (5).

7.1.2.2 The cone is made of high strength steel of a type and hardness suitable to resist wear due to abrasion by soil. Cone tips which have worn to the operating tolerance shown in Fig. 2 should be replaced. Piezocone tips should be replaced when the tip has worn appreciably (as shown) and the height of the cylindrical extension has reduced considerably (as shown).

NOTE 4—In some applications it may be desirable to scale the cone diameter down to a smaller projected area. Cone penetrometers with 5 cm² projected area find use in the field applications and even smaller sizes (1 cm²) are used in the laboratory for research purposes. These cones should be designed with dimensions scaled in direct proportion to standard

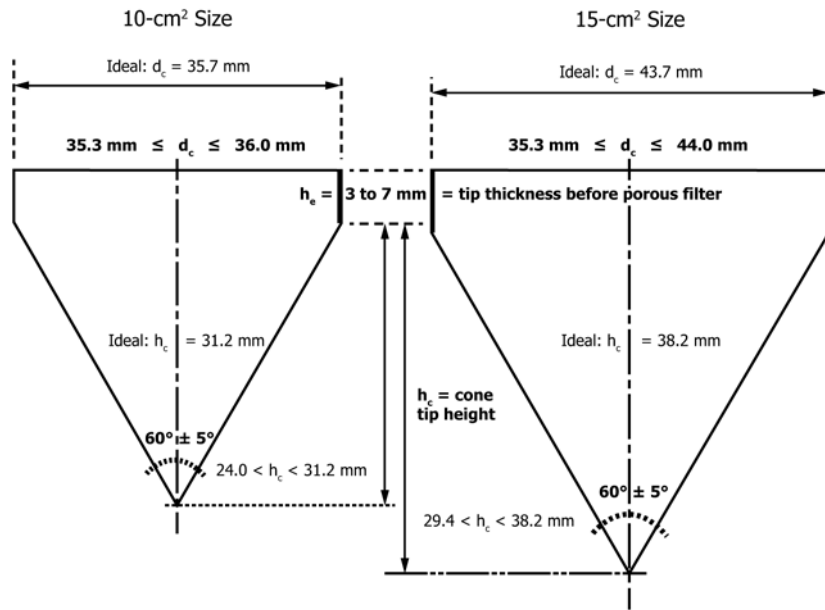

FIG. 2 Manufacturing and Operating Tolerances of Cones (5)

10-cm² penetrometers. In thinly layered soils, the diameter affects how accurately the layers may be sensed. Smaller diameter cones may sense thinner layers more accurately than larger cones. If there are questions as to the effect of scaling the penetrometer to either larger or smaller size, results can be compared in the field to the 10-cm² penetrometer for soils under consideration. This is because the 10-cm² cone is considered the reference penetrometer for field testing.

7.1.3 *Friction Sleeve*—The outside diameter of the manufactured friction sleeve and the operating diameter are equal to the diameter of the base of the cone with a tolerance of +0.35 mm and –0.0 mm. The friction sleeve is made from high strength steel of a type and hardness to resist wear due to abrasion by soil. Chrome-plated steel is not recommended due to differing frictional behavior. The surface area of the friction sleeve is 150 cm² ± 2 %, for a 10-cm² cone. If the cone base area is increased to 15 cm², as provided for in 7.1.2.1, the surface area of the friction sleeve should be adjusted proportionally, with the same length to diameter ratio as the 10-cm² cone. With the 15-cm² tip, a sleeve area of 225 cm² is similar in scale.

7.1.3.1 The top diameter of the sleeve must not be smaller than the bottom diameter or significantly lower sleeve resistance will occur. During testing, the top and bottom of the sleeve should be periodically checked for wear with a micrometer. Normally, the top of the sleeve will wear faster than the bottom.

7.1.3.2 Friction sleeves must be designed with equal end areas which are exposed to water pressures (1, 5, 6, 7, 8). This will remove the tendency for unbalanced end forces to act on the sleeve. Sleeve design must be checked in accordance with A1.7 to ensure proper response.

7.1.4 *Gap*—The gap (annular space) between the cylindrical extension of the cone base and the other elements of the penetrometer tip should be kept to the minimum necessary for operation of the sensing devices and should be designed and constructed in such a way to prevent the entry of soil particles.

Gap requirements apply to the gaps at either end of the friction sleeve and to other elements of the penetrometer tip.

7.1.4.1 The gap between the cylindrical extension of the cone base and other elements of the penetrometer tip, e_c , must not be larger than 5 mm for the friction cone penetrometer.

7.1.4.2 If a seal is placed in the gap, it should be properly designed and manufactured to prevent entry of soil particles into the penetrometer tip. It must have a deformability at least two orders of magnitude greater than the material comprising the load transferring components of the sensing devices in order to prevent load transfer from the tip to the sleeve.

7.1.4.3 *Filter Element in the Gap*—If a filter element for a piezocone is placed in the gap between cone and sleeve the sum of the height of cylindrical extension, h_e , plus element thickness filling the gap, e_c , can range from 8 to 20 mm (see 7.1.8 for explanation).

7.1.5 *Diameter Requirements*—The friction sleeve should be situated within 5 to 15 mm behind the base of the cone tip. The annular spaces and seals between the friction sleeve and other portions of the penetrometer tip must conform to the same specifications as described in 7.1.4. Changes in the diameter of the penetrometer body above the friction sleeve should be such that tip or sleeve measurements are not influenced by increases in diameter. International reference test procedures require that the penetrometer body have the same diameter as the cone for the complete length of the penetrometer body (5, 9, 10).

7.1.5.1 For some penetrometer designs, it may be desirable to increase the diameter of the penetrometer body to house additional sensors or reduce friction along push rods. These diameter changes are acceptable if they do not have significant influence on tip and sleeve data. If there is question regarding a specific design with diameter increases, comparison studies

can be made to a penetrometer with constant diameter. Information on diameters of the complete penetrometer body should be reported.

NOTE 5—The effects caused by diameter changes of the penetrometer on tip and sleeve resistance are dependent on the magnitude of diameter increase and location on the penetrometer body. Most practitioners feel that diameter increases equivalent to addition of a friction reducer with area increases of 15 to 20 % should be restricted to a location at least eight to ten cone diameters behind the friction sleeve.

7.1.6 The axis of the cone, the friction sleeve (if included), and the body of the penetrometer tip must be coincident.

7.1.7 *Force Sensing Devices*—The typical force sensing device is a strain gauge load cell that contains temperature compensated bonded strain gages. The configuration and location of strain gages should be such that measurements are not influenced by possible eccentricity of loading.

7.1.8 *Electronic Piezocone Penetrometer*—A piezocone penetrometer can contain porous filter element(s), pressure transducer(s), and fluid filled ports connecting the elements to the transducer to measure pore water pressure. Fig. 3 shows the common design types used in practice including: 10-cm² friction-type, type 1 and type 2 piezocone, and 15-cm² size. The standard penetrometer should be the type 2 piezocone with filter located at the shoulder (both 10-cm² and 15-cm²) to allow correction of tip resistances. The electric friction penetrometer

without porewater transducers can be used in soils with minor porewater pressure development, such as clean sands, granular soils, as well as soils and fills well above the groundwater table. The type 1 with face filter element finds use in fissured geomaterials and materials prone to desaturation, as well as dissipation readings. Numerous design and configuration aspects can affect the measurement of dynamic water pressures. Variables such as the element location, design and volume of ports, and the type and degree of saturation of the fluids, cavitation of the element fluid system and resaturation lag time, depth and saturation of soil during testing all affect the dynamic porewater pressure measured during testing and dissipation tests of dynamic pressures (2, 3, 4, 8). It is beyond the scope of the procedure to address all of these variables. As a minimum, complete information should be reported as to the design, configuration, and the preparation of the piezocone system that is used for the particular sounding.

7.1.8.1 Measurement of hydrostatic water pressures during pauses in testing are more straightforward. The presence of air entrained in the system only affects dynamic response. In high permeability soils (that is, clean sands), hydrostatic pressures will equalize within seconds or minutes. In low permeability materials such as high plasticity clays, equalization can take many hours. If the goal of the exploration program is only to

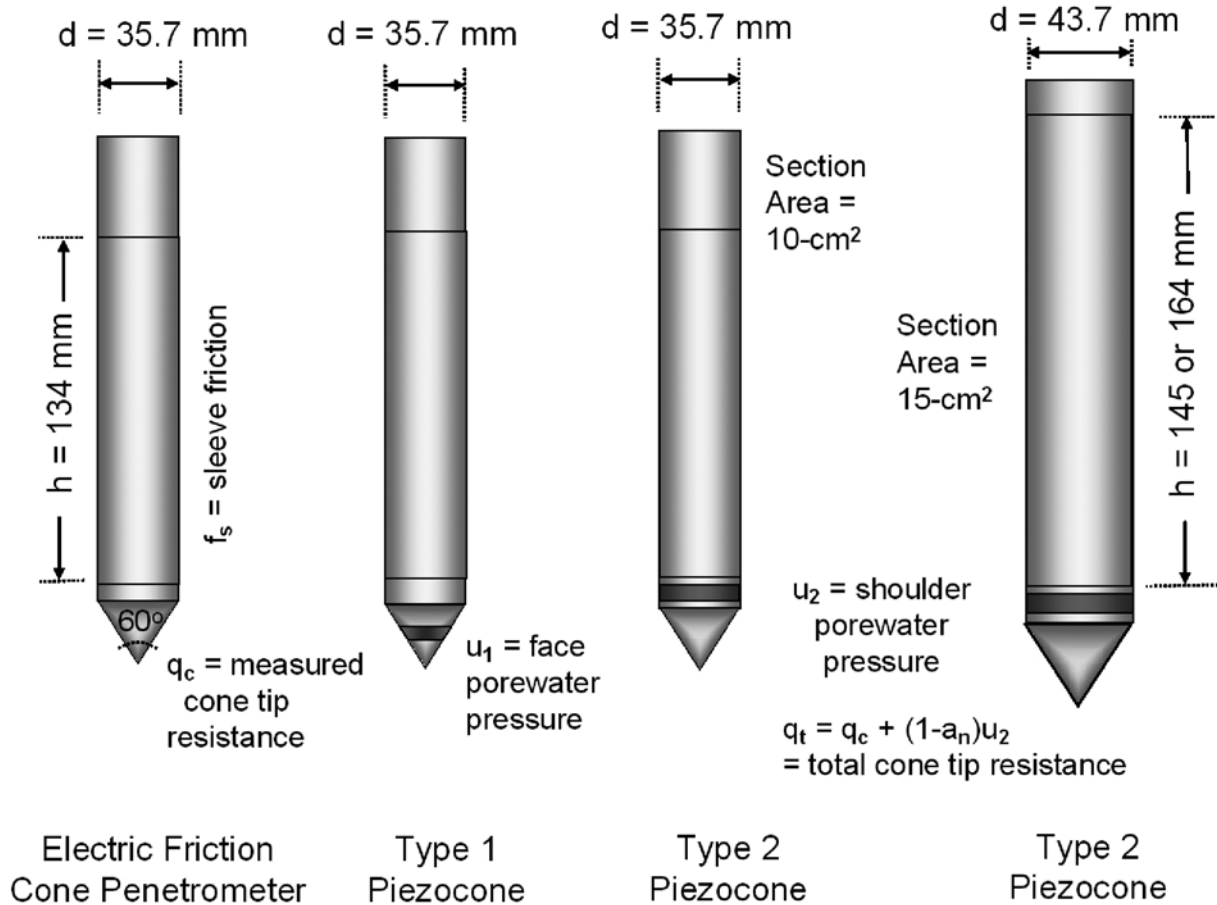

FIG. 3 Penetrometer Design Configurations: (a) Electric Friction-type, (b) Type 1 Piezocone, (c) Standard 10-cm² Type 2 Piezocone, and (d) 15-cm² Type 2 Version (7)

acquire hydrostatic pressures in sands, some of the preparation procedures for dynamic pressure measuring can be relaxed, such as deairing fluids.

7.1.8.2 The porewater pressure measurement locations of the porous element are limited to the face or tip of the cone, u_1 , directly behind the cylindrical extension of the base of the cone, u_2 , or behind the sleeve, u_3 . Some penetrometers used for research purposes may have multiple measurement locations.

7.1.8.3 There are several advantages to locating the porous element immediately behind the tip of the cone in location u_2 , primarily the required correction of measured q_c to total tip stress, q_t , as detailed extensively (4-8). Also, the element is less subject to damage and abrasion, as well as fewer compressibility effects (4, 8). Elements located in the u_2 location may be subject to cavitation at shallow depths in dense sands because the zone behind the height of cylindrical extension is a zone of dilation in drained soils. Similar response can occur in stiff fissured clays and crusts (4). Porewater pressure measurements obtained at the u_1 face location are more effective for compressibility determinations and layer detection, particularly in fissured soils, but are more subject to wear (3, 11). At the u_2 location, a minimum 2-mm cylindrical extension of the cone tip (h_c) should be maintained for protection of the cone. Typical filter element thickness at all locations in the horizontal plane ranges from 5 to 10 mm.

7.1.8.4 The miniature diaphragm-type electronic pressure transducer is normally housed near the tip of the cone. For dynamic pressure measurements, the filter and ports are filled with deaired fluid to measure dynamic porewater pressure response. The volume of connecting ports to the transducer should be minimized to facilitate dynamic pressure response. These electronic transducers are normally very reliable, accurate, and linear in response. The transducer shall have a precision of at least ± 14 kPa (± 2 psi). The porewater pressure transducer must meet requirements given in 10.2.

7.1.8.5 *Element*—The element is a fine porous filter made from plastic, sintered steel or bronze, or ceramic. Typical pore size is between 20 to 200 microns (8, 11). Different materials have different advantages. Smearing of metallic element openings by hard soil grains may reduce dynamic response of the system, thus normally not used for face elements but best suited for shoulder filter positions. Ceramic elements are very brittle and may crack when loaded, but perform well on the cone face as they reduce compressibility concerns. Polypropylene plastic elements are most commonly used in practice, particularly at the shoulder. Plastic filters (as high-density polyethylene, HDPE, or high-density polypropylene, HDPP) may be inappropriate for environmental type CPTs where contaminant detection is sought. Typically, the filter element is wedged at the tip or midface (u_1) location, or located at the shoulder in the gap immediately above the cone extension (designated u_2) location. At these locations, it is important to design the penetrometer such that compression of the filter elements is minimized.

7.1.8.6 *Fluids for Saturation*—Glycerine, or alternatively silicone oil, is most often used for deairing elements for dynamic response. These stiff viscous oils have less tendency to cavitate, although cavitation may be controlled by the

effective pore size of the element mounting surfaces. Water can be used for the fluid if the entire sounding will be submerged, or if dynamic response is not important. The fluids are deaired using procedures described in 11.2.

7.2 *Measuring System*—The signals from the penetrometer transducers are to be displayed at the surface during testing as a continuously updated plot against depth. The data are also to be recorded electronically for subsequent processing. Electronic recording shall be digital and use at least twelve bit (one part in 4096) resolution in the analog to digital conversion, although 16-bit resolution and higher may be preferable in very soft ground. Either magnetic (disk or tape) or optical (disk) non-volatile storage may be used. In analog systems, the temperature stability and accuracy of the A-to-D converter shall be such that the overall cone-transmission-recording system complies with calibration requirements set forth in the annex.

7.2.1 Use of analog systems is acceptable but the system resolution may be lower than requirements in the annex and Section 10. Use of an analog recorder as a supplement to digital system is advantageous because it can provide system backup.

NOTE 6—Depending upon the equipment, data stored digitally on magnetic drives, tapes, floppy disks, or other media are often used. The data files should include project, location, operator, and data format information (for example, channel, units, corrected or uncorrected, etc.) so that the data can be understood when reading the file with a text editor.

7.3 *Push Rods*—Steel rods are required having a cross sectional area adequate to sustain, without buckling, the thrust required to advance the penetrometer tip. For penetrometers using electrical cables, the cable is prestrung through the rods prior to testing. Push rods are supplied in 1-meter lengths. The push rods must be secured together to bear against each other at the joints and form a rigid-jointed string of push rods. The deviation of push rod alignment from a straight axis should be held to a minimum, especially in the push rods near the penetrometer tip, to avoid excessive directional penetrometer drift. Generally, when a 1-m long push rod is subjected to a permanent circular bending resulting in 1 to 2 mm of center axis rod shortening, the push rod should be discarded. This corresponds to a horizontal deflection of 2 to 3 mm at the center of bending. The locations of push rods in the string should be varied periodically to avoid permanent curvature.

7.3.1 For the 10-cm² penetrometer, standard 20-metric ton high tensile strength steel push rods are 36-mm outside diameter, 16-mm inside diameter, and have a mass per unit length of 6.65 kg/m. For 15-cm² penetrometers, the test may be pushed with 44.5-mm outside diameter rods or with standard rods used for the 10-cm² penetrometer.

7.4 *Friction Reducer*—Friction reducers are normally used on the push rods to reduce rod friction. If a friction reducer is used, it should be located on the push rods no closer than 0.5 m behind the base of the cone. Friction reducers, that increase push rod outside diameter by approximately 25 %, are typically used for 10-cm² cones. If a 15-cm² penetrometer is advanced with 36-mm push rods there may be no need for friction reducers since the penetrometer itself will open a larger hole.

The type, size, amount, and location of friction reducer(s) used during testing must be reported.

7.5 Thrust Machine and Reaction—The thrust machine will provide a continuous stroke, preferably over a distance greater than 1 m. The thrust machine should be capable of adjusting push direction through the use of a leveling system such that push initiates in a vertical orientation. The machine must advance the penetrometer tip and push rods at a smooth, constant rate (see 12.1.2) while the magnitude of thrust can fluctuate. The thrust machine must be anchored or ballasted, or both, so that it provides the necessary reaction for the penetrometer and does not move relative to the soil surface during thrust.

NOTE 7—Cone penetration soundings usually require thrust capabilities ranging from 100 to 200 kN (11 to 22 tons) for full capacity. High mass ballasted vehicles can cause soil surface deformations which may affect penetrometer resistance(s) measured in near surface layers. Anchored or ballasted vehicles, or both, may induce changes in ground surface reference level. If these conditions are evident, they should be noted in reports.

7.6 Other Sensing Devices—Other sensing devices can be included in the penetrometer body to provide additional information during the sounding. These instruments are normally read at the same continuous rate as tip, sleeve, and porewater pressure sensors, or alternatively, during pauses in the push (often at 1-m rod breaks). Typical sensors are inclinometer, temperature, resistivity (or its reciprocal, electrical conductivity), or seismic sensors, such as geophones that can be used to obtain downhole shear wave velocity. These sensors should be calibrated if their use is critical to the investigation program. The use of an inclinometer is highly recommended since it will provide information on potentially damaging situations during the sounding process. An inclinometer can provide a useful depth reliability check because it provides information on verticality. The configuration and methods of operating such sensors should be reported.

8. Reagents and Materials

8.1 O-Ring Compound—A petroleum or silicon compound for facilitating seals with O-rings. Use of silicon compounds may impede repair of strain gages if the strain gauge surface is exposed to the compound.

8.2 Glycerine, or $\text{CHOH}(\text{CH}_2\text{OH})_2$, for use in porewater pressure measurement systems. Approximately 95 % pure glycerine can be procured from most drug stores.

8.3 Silicone Oil (or fluid), for use in porewater pressure measurement systems. This material is available in varying viscosities ranging from 1400 to 10 000 CP.

NOTE 8—Detailed comparisons and discussions on the use of these fluids can be found elsewhere (8, 11).

9. Hazards

9.1 Technical Precautions—General:

9.1.1 Use of penetrometer components that do not meet required tolerances or show visible signs of non-symmetric wear can result in erroneous penetration resistance data.

9.1.2 The application of thrust in excess of rated capacity of the equipment can result in damage to equipment (see Section 6).

9.1.3 A cone sounding must not be performed any closer than 25 borehole diameters from any existing unbackfilled or uncased bore hole.

9.1.4 When performing cone penetration testing in prebored holes, an estimate of the depth below the prebored depth which is disturbed by drilling, should be made and penetration resistance data obtained in this zone should be noted. Usually, this depth of disturbance is assumed to be equal to at least three borehole diameters.

9.1.5 Significant bending of the push rods can influence penetration resistance data. The use of a tubular rod guide is recommended at the base of the thrust machine and also in prebored holes to help prevent push rod bending.

9.1.6 Push rods not meeting requirements of 7.3 may result in excessive directional penetrometer drift and possibly unreliable penetration resistance values.

9.1.7 Passing through or alongside obstructions may deflect the penetrometer and induce directional drift. Note any indications of encountering such obstructions, such as gravels, and be alert for possible subsequent improper penetrometer tip operation.

9.1.8 If the proper rate of advance of the penetrometer is not maintained for the entire stroke through the measurement interval, penetration resistance data will be erroneous.

9.2 Technical Precautions—Electronic Friction Cone Penetrometer:

9.2.1 Failure of O-ring seals can result in damage to or inaccurate readings from electronic transducers. The O-ring seals should be inspected regularly, after each sounding, for overall condition, cleanliness and watertightness.

9.2.2 Soil ingress between different elements of a penetrometer tip can result in unreliable data. Specifically, soil ingress will detrimentally affect sleeve resistance data. Seals should be inspected after each sounding, maintained regularly, and replaced when necessary. If very accurate sleeve resistance data is required, it is recommended to clean all seals after each sounding.

9.2.3 Electronic cone penetrometer tips should be temperature compensated. If extreme temperatures outside of the range established in A1.3.3 are to be encountered, the penetrometer should be checked for the required temperature range to establish they can meet the calibration requirements. Also, harsh environments may severely affect the data acquisition system of power supplies, notebook or field computers, and other electronics.

9.2.4 If the shift in baseline reading after extracting the penetrometer tip from the soil is so large that the conditions of accuracy as defined in 10.1.2.1 are no longer met, penetration resistance data should be noted as unreliable. If baseline readings do not conform to allowable limits established by accuracy requirements in 10.1.2.1, the penetrometer tip must be repaired, and recalibrated or replaced.

9.2.5 Electronic friction cone penetrometers having unequal end areas on their friction sleeves can yield erroneous f_s .

readings because of dynamic porewater pressures acting unevenly on the sleeve (**1, 5, 6, 8**). Friction sleeve design should be checked in accordance with **A1.7** to ensure balanced response. The response is also dependent on location of water seals. If O-ring water seals are damaged during testing, and sleeve data appear affected, the sounding data should be noted as unreliable and the seals should be repaired.

9.3 Piezocone Penetrometer—The electronic piezocone penetrometer tip measures pore water pressures on the exterior of the penetrometer tip by transferring the pressure through a de-aired fluid system to a pressure transducer in the interior of the tip. For proper dynamic response, the measurement system (consisting of fluid ports and porous element) must be completely saturated prior to testing. Entrained air must be removed from the fluid-filled system or porewater pressure fluctuation during penetrometer tip advancement will be incorrect due to response lag from compression of air bubbles (see **11.2, 12.3.2, and 12.3.3**). For soundings where dynamic response is important, the prepared filter elements should be replaced after every sounding.

10. Calibration and Standardization

10.1 *Electronic Friction Cone Penetrometers:*

10.1.1 The requirements for newly manufactured or repaired cone penetrometers are of importance. Newly manufactured or repaired electronic cone penetrometers are to be checked to meet the minimum calibration requirements described in the annex. These calibrations include load tests, thermal tests, and mechanical tests for effects of imbalanced hydrostatic forces. Calibration procedures and requirements given in the annex are for subtraction-type cone penetrometers. Calibration requirements for independent-type cone penetrometers should equal or exceed those requirements. The calibration records must be certified as correct by a registered professional engineer or other responsible engineer with knowledge and experience in materials testing for quality assurance. Applied forces or masses must be traceable to calibration standard forces or masses retained by the National Institute of Standards and Technology (NIST), formerly the National Bureau of Standards. For description of calibration terms and methods for calibrating, refer to the annex.

10.1.2 Baseline Readings—Baseline or zero-load readings for both cone and friction sleeve load cells and porewater pressure transducers must be taken before and after each sounding. The baseline reading is a reliable indicator of output stability, temperature-induced apparent load, soil ingress, internal friction, threshold sensitivity, and unknown loading during zero setting. Take the initial baseline reading after warming electrical circuits according to the manufacturer's instructions, generally for 15 to 30 min, and in a temperature environment as close as possible to that of the material to be sounded. If temperature is of concern, immerse the penetrometer tip in a bucket of fresh tap water, or insert the penetrometer tip in the ground while electrically warming circuits to stabilize its temperature and then extracted for rapid determination of initial baseline. After a sounding is completed, take a final

baseline. The change in initial and final baseline values should not exceed 2 % FSO for the cone tip, sleeve, and pressure transducer.

10.1.2.1 Maintain a continuous record of initial and final baselines during production testing. After each sounding, compare the final baseline to the initial baseline for agreement within the tolerances noted above. In some cases during heavy production testing where the cone is not disassembled and cleaned after each sounding, the initial baseline for the next sounding can serve as the final baseline to the previous sounding as long as agreement is within allowable limits.

10.1.2.2 If the post sounding baseline shift exceeds above criteria, inspect the cone for damage by inspecting the tip and checking to see that the sleeve can be rotated by hand. If there is apparent damage, replace parts as required. Clean the cone and allow temperatures to equalize to presounding conditions, and obtain a new baseline. If this value agrees with the initial baseline within the above criteria, a load range calibration check is not required. If the pre and post baselines are still not within the above criteria then it is likely that the shift was caused by an obstacle or obstruction and linearity should be checked with a load range calibration.

10.1.2.3 If the baseline shift still exceeds the above criteria, perform a load range calibration as described in **10.1.2.1**. If the cone load cell baseline shift exceeds 2 % FSO, the cone is likely damaged and will not meet load range criteria in **10.1.2.2**. Sleeve load cell baseline shifts for subtraction-type penetrometers usually can exceed 2 % FSO and still meet load range criteria.

10.1.2.4 Report data for the sounding where unacceptable baseline shift occurs as unreliable. In some cases it may be obvious where the damage occurred and data prior to that point may be considered reliable. The location where obvious damage occurred should be clearly noted in reports.

10.1.3 *Penetrometer Wear and Usage*

10.1.3.1 For penetrometers used regularly during production, periodic load range checks should be performed. The inspection period can be based on production footage such as once every lineal 3000 m (approx. 10⁴ linear feet) of soundings. If field load range equipment is not available, the penetrometer may be checked in the laboratory at the end of a project.

10.1.3.2 For penetrometers that are used infrequently, a periodic check may be based on time period, such as once every year. If a penetrometer has not been used for a long period of time, checking it before use is advisable.

10.1.3.3 For projects requiring a high level of quality assurance, it may be required to do load range checks before and after the project.

10.1.3.4 Load range calibrations are required if the initial and final baselines for a sounding do not meet requirements given in **10.1.2.1**.

10.1.3.5 Records documenting the history of an individual penetrometer should be maintained for evaluation of performance.

10.2 Porewater Pressure Transducer—Calibrate newly manufactured or repaired transducers in accordance with requirements in the annex. During production, the transducer

should be calibrated at regularly scheduled intervals and whenever linear performance is suspect. The reference gauge can be a Bourdon tube pressure gauge, or electronic pressure transducer that is calibrated annually to NIST traceable loading device (dead weight testing apparatus).

10.2.1 Prior to testing, baseline values or initial zeroing of the transducer is performed on the porewater pressure transducer at ambient air pressures at the surface. Maintain records as to the baseline values for the transducer in similar fashion to those for tip and sleeve resistance. If significant changes in baseline values occur, normally 1 to 2 % FSO, perform load range tests to check for possible damage and nonlinear response.

10.3 *Calibrations of Other Sensing Devices*—Calibration data for other sensors in the penetrometer body may require calibrations using procedures similar to those given in the annex for load cells and pressure transducers. The need for calibration depends on the requirements of the individual investigation program. For noncritical programs, the occurrence of reasonable readings may be sufficient. In critical programs, it may be necessary to load the sensor through the range of interest with reference standards to ensure accurate readings.

11. Conditioning

11.1 Power electronic cone penetrometer and data acquisition systems for a minimum time period to stabilize electric circuits before performing soundings. Power the system to manufacturer's recommendations prior to obtaining reference baselines. For most electronic systems this time period is 15 to 30 min.

11.2 Electronic piezocone penetrometer soundings require special preparation of the transmitting fluid and porous elements such that entrained air is removed from the system. For soundings where dynamic response is important, replace the prepared filter elements and the ports flushed after every sounding. Some of the techniques discussed below have been successful for preparation of elements. Regardless of the techniques used, report the equipment and methods.

11.2.1 Field or laboratory tests can be performed to evaluate assembled system response, if desired. Place the cone tip and element in a pressurized chamber and subject to rapid pressure change. Compare the response of the system to the applied pressure changes and if responses match, the system is properly prepared.

11.2.2 Place elements in a pure glycerine or silicone oil bath under a vacuum of at least 90 % of one atmosphere (–90 kPa). Maintain vacuum until air bubble generation is reduced to a minimum. Application of ultrasonic vibration and low heat ($T < 50^{\circ}\text{C}$) will assist in removal of air. Generally with use of combined vacuum, ultrasonic vibration, and low heat, filter elements can be deaired in about 4 h, although it is best to allow for 24 h to ensure best performance. Results will depend upon the viscosity of the fluid and pore size of the filter element.

11.2.3 Elements can be prepared in water by boiling the elements while submerged in water for at least 4 h, although damage may result from prolonged exposure in this approach (4).

11.2.4 *Other Suitable Means*—Report other techniques, such as commercially-purchased pre-saturated filter elements that are available, or grease-filled slot (1, 7).

11.2.5 *Storage*—Store prepared elements submerged in the prepared fluid until ready for use. Fill the containers and evacuate during storage. Allowable storage length depends on the fluid. If elements are prepared in water they must be deaired again one day after containers are opened and exposed to air. Elements stored in glycerine or silicone may be stored for longer periods, up to several months, after storage containers have been exposed to air.

12. Procedure

12.1 General Requirements:

12.1.1 Prior to beginning a sounding, perform site surveys to ensure hazards such as overhead and underground utilities will not be encountered. Position the thrust machine over the location of the sounding, and lower leveling jacks to raise the machine mass off the suspension system. Set the hydraulic rams of the penetrometer thrust system to as near vertical as possible. The axis of the push rods must coincide with the thrust direction.

12.1.2 Set the hydraulic ram feed rate to advance the penetrometer at a rate of 20 ± 5 mm/s for all electronic cone penetrometers. This rate must be maintained during the entire stroke during downward advance of the rods while taking readings.

12.1.3 Check push rods for straightness and permanent bending (See Section 7.3). Push rods are assembled and tightened by hand, but care must be taken and threads may need cleaning to ensure that the shoulders are tightly butted to prevent damage to the push rods. For electronic cone penetrometers using cables, the cable is prestrung through the push rods. Add friction reducer to the string of push rods as required, usually the first push rod behind the penetrometer tip and other rods as required.

12.1.4 Inspect penetrometer tips before and after soundings for damage, soil ingress, and wear. In very soft and sensitive soils where accurate sleeve data is required, dismantle electronic cone penetrometer tips and friction sleeves after each sounding to clean and lubricate as required. If damage is found after a sounding, note and record this information on the sounding data record or report.

12.2 Friction Cone Penetrometers:

12.2.1 Power up the penetrometer tip and data acquisition system according to the manufacturer's recommendations, typically 15 to 30 min, prior to use.

12.2.2 Obtain an initial baseline reading for the penetrometer in an unloaded condition at a temperature as close as possible to ground conditions. Obtain baseline readings with the penetrometer tip hanging freely in air or in water, out of direct sunlight. Compare baseline readings with the previous baseline reading for the requirements given in 10.1.2.1. If

thermal stability needs to be assured, immerse the penetrometer tip in water at temperature close to ground; or perform an initial short penetration test hole, stop penetration and allow the penetrometer tip to reach soil temperature, and withdraw the penetrometer.

12.2.3 Measure the depth at which readings were taken with an accuracy of at least ± 100 mm from the ground surface.

12.2.4 Determine the cone resistance and friction sleeve resistance, continuously with depth, and record the data at intervals of depth not exceeding 50 mm.

12.2.5 During the progress of sounding, monitor tip and sleeve forces continuously for signs of proper operations. It is helpful to monitor other indicators such as ram pressure or inclination to ensure that damage may not occur if highly resistant layers or obstructions are encountered. Inclination is a particularly useful indicator of imminent danger to the system (see 12.4).

12.2.6 At the end of a sounding, extract the penetrometer tip, obtain a final set of baseline readings with the penetrometer tip hanging freely in air or in water, and check them against the initial baseline. Record initial and final baselines on all documents related to the sounding.

12.3 *Electronic Piezocone Penetrometers:*

12.3.1 Power up the penetrometer tip and data acquisition system according to the manufacturer's recommendations, typically 15 to 30 min, prior to use.

12.3.2 Assemble the piezo elements with all fluid chambers submerged in the de-aired medium used to prepare the elements. Flush all confined areas with fluid to remove air bubbles. Tighten the cone tip to effectively seal the flat surfaces. For water fluid systems, protect the assembled system from evaporation by enclosing the porous element inside a fluid-filled plastic bag or cap sealed to the penetrometer tip.

12.3.3 If unsaturated soil is first penetrated and it is desired to obtain accurate dynamic porewater pressure response once below the ground water, it may be necessary to prebore or sound a pilot hole to the water table. In many cases, the piezocone fluid system may cavitate during penetration through unsaturated soil or in dilating sand layers below the water table and this can adversely affect dynamic response. As the cone is advanced deeper, the saturation levels may recover as air bubbles are driven back into solution according to Boyles Law. Evaluation of proper interpretation of dynamic response requires experience (4, 5, 8, 12). Pre-punching or pre-boring with a two-level phase approach to soundings may help alleviate desaturation problems.

12.3.4 Record baseline readings with the penetrometer tip hanging freely in air, or in water, out of direct sunlight. Compare baseline readings with reference baseline readings for requirements given in 10.1.2.1 and 10.2. A baseline for the porewater pressure transducer is obtained immediately after assembly to avoid evaporation effects. If evaporation is a problem, temporarily immerse the penetrometer in a bucket of water until ready for baseline. Do not obtain transducer baselines with protective caps or covers in place as these may induce pressure in the system. Note the pressure from the pressure transducer to see if it is a reasonable value for the equipment and assembly technique used.

12.3.5 Follow procedures similar to electric friction cone in 12.2.4 – 12.2.6 with the addition of recording porewater pressure readings.

12.3.6 *Dissipation Tests*—If dissipation tests are to be conducted during progress of the sounding, penetration is temporarily stopped at the location of interest. If porewater pressures are measured at the u_2 or u_3 locations, it is common practice to release the force on the push rods. If porewater pressures are measured at the midface location u_1 , maintain the force on the push rods. Record porewater pressure versus time during conduct of the dissipation test. Monitor pressures until equilibrium porewater pressure is reached or 50 % of the initial excess porewater pressure has dissipated. In fine grained soils of very low conductivity, very long times may be required to reach the 50 % dissipation. Depending on the requirements of the program, and any concern of friction buildup on the push rods, dissipation testing may be terminated prior to reaching the 50 % level. Report dissipation test data as a record of porewater pressure versus time, or more commonly, u versus logarithm of time.

12.3.7 *Hydrostatic Porewater Condition*—If full dissipations are carried out, then the porewater transducer will eventually record the hydrostatic condition, thus providing an evaluation of the position of the groundwater table or phreatic surface.

12.4 *Penetrometer Operation and Data Interpretation-Guidelines:*

12.4.1 *Directional Drift of Penetrometer:*

12.4.1.1 The penetrometer may drift directionally from vertical alignment. Large deviations in inclination can create nonuniform loading and result in unreliable penetration resistance data. Reduce drift by accurately setting thrust alignment and using push rods which meet tolerances given in 7.3.

12.4.1.2 Passing through or alongside obstructions such as boulders, cobbles, coarse gravel, soil concretions, thin rock layers, or inclined dense layers will deflect the penetrometer tip and induce drifting. Note and record any indication of encountering such obstructions, and be alert for possible subsequent improper penetrometer tip operations as a sign of serious directional drift.

12.4.1.3 Penetrometer inclination is typically monitored in cone penetrometers. Impose limitations on inclination in the system to prevent damage to push rods and non-symmetric loading of the penetrometer tip. Generally, a 5° change in inclination over 1 m of penetration can impose detrimental push rod bending. Total drift of over 12° in 10 m of penetration imposes non-symmetric loading and possible unreliable penetration resistance data.

12.4.2 *Push Rod Addition Interruptions*—Short duration interruptions in the penetration rate during addition of each new push rod can affect initial cone and friction sleeve readings at the beginning of the next push. If necessary, note and record the depths at which push rods are added and where long pauses may have affected initial startup resistances.

12.4.3 *Piezocone Porewater Pressure Dissipation Interruptions*—Porewater pressure dissipation studies, for which soundings are stopped and rod load is released for varying time durations, can affect the initial cone, friction

sleeve, and dynamic porewater pressure readings at resumptions of cone penetration. If dissipation tests are performed, be aware of possible rebound effects on initial excess porewater pressures. Note and record the depth and duration for which dissipation values are taken.

12.4.4 Interruptions Due to Obstructions—If obstructions are encountered and normal advance of the sounding is stopped to bore through the obstructions, obtain further penetration resistance data only after the penetrometer tip has passed through the estimated zone of disturbance due to drilling. As an alternative, readings may be continued without first making the additional penetration and the disturbed zone evaluated from these data. Note and record the depth and thickness of obstructions and disturbed zones in areas where obstructions are drilled through.

12.4.5 Excessive Thrust Capacity—If excessive thrust pressure begins to impede the progress of the sounding, it may be necessary to withdraw and change friction reducers. Alternately, sometimes friction may be reduced by withdrawing the penetrometer and rods up to one third to one half of the penetration depth and then repushing to depth at which the friction caused stopping. Continue collection of sounding data from the point of stopping. Note and record the delay time and depths to which the penetrometer was moved. Long delays and pauses may cause buildup of friction on the rods. Hold delays to the minimum required to perform dissipation tests or equipment repairs.

12.4.5.1 If a high resistance layer is encountered, and the hydraulic thrust machine is physically moved during penetration, terminate the sounding. Another indicator of reaching thrust capacity is the rebound of rods after they are released. The magnitude of rebound depends on the flexibility of the thrust machine and the push rods. An operator must become familiar with the safe deflection of the system and decide when excessive deflections are being reached.

12.4.6 Unusual Occurrences—As data are recorded, it is important to note unusual occurrences in testing. When penetrating gravels, it is important to note “crunching” sounds that may occur when particle size and percentage of coarse particles begin to influence penetration. Note and report all occurrences of coarse gravels.

12.5 Withdrawal:

12.5.1 Withdraw the push rods and penetrometer tip as soon as possible after attaining complete sounding depth.

12.5.2 Upon complete withdrawal of the penetrometer, inspect the penetrometer tip for proper operation. The friction sleeve should be able to be rotated through 360° by hand without detectable binding.

12.5.3 Record baseline readings with the penetrometer tip hanging freely in air, or in water, out of direct sunlight. Compare baseline readings with initial baseline reading for requirements given in **10.1.2.1**.

12.6 Hole Closure—In certain cases, it may be prudent or required by state law or specifications, that the cone hole be filled, sealed, or grouted and closed after the sounding is completed. For example, in complex groundwater regimes,

hole closure should be made to protect the water aquifer. Details on various methods for hole closure are provided elsewhere (**13**).

13. Calculation

13.1 Friction Cone Penetrometers—Most electronic cone penetrometers in use at the present time measure a change in voltage across a strain gauge element to determine change in length of the strain element. Using known constitutive relationships between stress and strain for the strain element, the applied force may be determined for the cone or friction sleeve. The applied force may then be converted to stresses using the basic equations given in **13.2** and **13.3**. Since there are a wide variety of additional, optional measurements currently being obtained with electronic cone penetrometers and new ones being continually developed, it is beyond the scope of this procedure to detail the makeup, adjustments, and calculations for these optional measurements.

13.2 Cone Resistance, q_c —Required:

$$q_c = Q_c / A_c \quad (1)$$

where:

q_c = cone resistance MPa (for example, ton/ft², kg_f/cm², or bar),

Q_c = force on cone kN (for example, ton, or kg_f), and

A_c = cone base area, typically 10 cm², or 15 cm².

13.2.1 Corrected Total Cone Resistance (Required)—Calculation of corrected total cone resistance requires measurement of porewater pressures measured at the shoulder in the u_2 position.

$$q_t = q_c + u_2 (1 - a_n) \quad (2)$$

where:

q_t = corrected total cone resistance, MPa (ton/ft², kg_f/cm², bar, or suitable units for stress),

u_2 = porewater pressure generated immediately behind the cone tip, kPa (for example, tsf, kg_f/cm², bar, or suitable units for pressure), and

a_n = net area ratio (see **A1.7**).

13.2.1.1 The correction to total cone resistance is particularly important when porewater pressures are generated during penetration (for example, saturated clays, silts, and soils with appreciable fines). Generally, the correction is not so significant for CPTs in clean sands, dense to hard geomaterials, and dry soils. The correction is due to porewater pressures acting on opposing sides of both the face and joint annulus of the cone tip (**4, 1, 6, 8**).

NOTE 9—In all cases, the total value q_t should be used, substituted for (or both) q_c , wherever possible. In no cases should q_c be backdetermined from q_t for use in equations, charts, formulae, or other purposes. It is always a forward procedure with corrected total q_t to be preferred.

13.2.1.2 Empirical adjustment factors based on select soil types have been developed for some pressure elements in the u_1 position, however these are not reliable. On a site-by-site basis, a relationship between u_1 and u_2 may be possible.

13.3 Friction Sleeve Resistance, f_s —Required:

$$f_s = Q_s / A_s \quad (3)$$

where:

- f_s = friction sleeve resistance kPa (ton/ft², kg_f/cm², bar, or suitable units for stress),
 Q_s = force on friction sleeve kN (ton, kg_f, or suitable units for force), and
 A_s = area of friction sleeve, typically 150 cm² for 10-cm² tip, or 200 to 300 cm² for larger 15-cm² cones.

NOTE 10—A corrected sleeve friction resistance may also be obtained (f_c), yet this requires both u_2 and u_3 measurements simultaneously (2, 3, 1, 5, 6, 8). Thus, the raw f_s has been accepted for practical reasons. A simplified correction has been adopted by selected organizations (for example, (8)).

13.4 Friction Ratio, R_f —(Optional):

$$R_f = (f_s/q_c) \cdot 100 \quad (4)$$

where:

- R_f = friction ratio, %,
 f_s = friction sleeve resistance kPa (ton/ft², kg_f/cm², bar, or suitable units for stress),
 q_c = cone resistance kPa (ton/ft², kg_f/cm², bar, or suitable units for stress) (See Note 2 for use of q_c), and
 100 = conversion from decimal to percent.

13.4.1 Determination of the friction ratio requires obtaining a cone resistance and friction sleeve resistance at the same point in the soil mass. The point of the cone is taken as the reference depth. Typically, a previous cone tip resistance reading at friction sleeve midpoint depth is used for the calculations. For the 10-cm² penetrometer, the standard offset is 100 mm. If an offset other than midheight is used it must be reported.

NOTE 11—In some cases, if readings are compared at the same point in a soil mass which has alternating layers of soft and hard materials erratic friction ratio data will be generated. This is because cone resistance is sensed, to varying degrees, ahead of the cone. The erratic data may not be representative of soils actually present.

NOTE 12—The friction sleeve resistance and friction ratio obtained from the mechanical friction cone penetrometers will differ considerably from values obtained from electronic friction cone penetrometers. When using soil classification charts that use R_f and q_c , it is important to use charts based on correlations for the type of penetrometer being used.

13.5 Porewater Pressure Data:

13.5.1 SI metric units for reporting porewater pressure data are kPa.

13.5.2 Conversion of Measured Porewater Pressures to Equivalent Height of Water—Optional—If it is desired to display porewater pressure in equivalent height of water, convert the dynamic or static water pressures to height by dividing pressure by the unit weight of freshwater, $\gamma_w = 9.8$ kN/m³ (62.4 lb_f/ft³). For salt water, use $\gamma_w = 10.0$ kN/m³ (64.0 lb_f/ft³).

13.5.3 Estimate of Equilibrium Porewater Pressure—Excess porewater pressure can only be calculated by knowing equilibrium pore water pressure, u_o (see 3.2.14). The equilibrium water pressure can be measured by dissipation test or estimated by calculation as follows:

$$u_o = \text{estimated equilibrium water pressure} = h_w \cdot \gamma_w \quad (5)$$

In saturated soils below the groundwater level, the hydrostatic case is obtained from:

$$u_o = (z - z_w) \gamma_w \quad (6)$$

For soils above the groundwater table that are saturated due to full capillarity, Eq 6 is also applicable. For dry soils above the groundwater table, it is commonly adopted that $u_o = 0$. In partially-saturated soils (vadose zone), there can be great transient variations and variability in the u_o profile.

where:

- h_w = height of water, m (or feet), evaluate from site conditions,
 γ_w = unit weight of (fresh) water = 9.8 kN/m³ (or 62.4 lbs/ft³),
 z = depth of interest (m or feet), and
 z_w = depth to the groundwater table (phreatic surface).

In layered soils with multiple perched aquifers the assumption of a single height of water may be in error.

13.6 Normalized CPT Measurements In the latest soil behavioral classification charts and CPT interpretation methods, normalized readings for cone tip resistance, sleeve friction, and porewater pressure are utilized (1, 6, 14), as defined below.

13.6.1 Normalized cone tip resistance:

$$Q = (q_t - \sigma_{vo})/\sigma_{vo}' \quad (7)$$

13.6.2 Normalized Porewater Pressure Parameter, B_q —This parameter is normally calculated with the shoulder porewater pressure measurement (location immediately behind the cone tip), designated u_2 .

$$B_q = \Delta u/(q_t - \sigma_{vo}) \quad (8)$$

13.6.3 Normalized friction ratio:

$$F = f_s/(q_t - \sigma_{vo}) \quad (9)$$

where:

- Δu = excess pore water pressure ($u_2 - u_o$) (see 3.2.13),
 u_o = estimated equilibrium water pressure, or hydrostatic porewater (see 13.5.3),
 σ_{vo} = total vertical overburden stress, and
 σ_{vo}' = effective overburden stress = $\sigma_{vo} - u_o$

The total overburden stress is calculated:

$$\sigma_{vo} = \sum (\gamma_{ii} \Delta z_i) \quad (10)$$

where:

- Δz_i = layer thickness, and
 γ_{ii} = total soil unit weight for layer.

14. Report

14.1 Report the following information:

14.1.1 General—Each sounding log should provide as a minimum:

- 14.1.1.1 Operator name,
 - 14.1.1.2 Project information,
 - 14.1.1.3 Feature notes,
 - 14.1.1.4 Ground surface elevation and water surface elevation (if available),
 - 14.1.1.5 Sounding location, including coordinates
 - 14.1.1.6 Sounding number, and
 - 14.1.1.7 Sounding date.
- 14.1.2 Reports should contain information concerning:

14.1.2.1 *Equipment Used*—Design drawings and data on all sensors,

14.1.2.2 Graphical data,

14.1.2.3 Electronic digital data or tabular data (optional),

14.1.2.4 Procedures followed, and

14.1.2.5 *Calibration Information*—For all sensors, information required in Section 10.

14.1.3 The report should contain a text that discusses items required in 14.2 and 14.3. Each sounding should be documented with:

14.1.3.1 Sounding plot.

14.1.3.2 *Accompanying Tabular Output*—Tabular output is considered optional due to its bulk. It is optional as long as computer data files are preserved and archived for later use.

14.1.3.3 *Computer Data Files*—Provide in ASCII format, spreadsheet file, or text, or other common file format. Computer data files must contain header as required in 14.1, sounding log information. Certain interpretation programs require data to be in a particular format. It is the responsibility of the user to determine acceptable formats.

14.1.3.4 The comments should contain notes on equipment and procedures, particular to the individual sounding.

14.2 *Equipment*—The report should include notes concerning:

14.2.1 Penetrometer manufacturer,

14.2.2 Types of penetrometer tips used,

14.2.3 Penetrometer details such as net area ratio, friction sleeve end areas, location and types of sensors, location and type of friction reducers,

14.2.4 Offset between tip and sleeve resistance used for friction ratio determination,

14.2.5 Serial numbers of penetrometer tips,

14.2.6 Type of thrust machine,

14.2.7 Method used to provide reaction force—with notes as to possible surface deformations,

14.2.8 Location and type of friction reduction system (if any),

14.2.9 Method of recording data,

14.2.10 Condition of push rods and penetrometer tip after withdrawal,

14.2.11 Any special difficulties or other observations concerning performance of the equipment,

14.2.12 Details on piezocone design, filter elements, and fluid conditioning procedures, and

14.2.13 Information on other sensing devices used during the sounding.

14.3 *Calibration Certifications*—For each project the report should include the load range calibrations of the cones used that were performed in accordance with Section 10. The report should include the initial and final baseline readings for each sounding. Calibration records for the porewater pressure transducers are required as given in 10.2. If the project requires calibrations of other sensors they should also be submitted in final reports.

14.4 *Graphs*—Every report of friction cone penetration sounding is to include a cone tip resistance plot, q_c MPa, or preferably total cone tip resistance, q_t MPa (or ton/ft², kg/cm², bar, or other acceptable unit of stress) with depth below ground surface m (ft), friction sleeve resistance, f_s , kPa (ton/ft², kg/cm², bar, or other acceptable units of stress), and friction ratio, R_f (%), on the same plot. (See Fig. 4 and Fig. 5 for example plots.) As a minimum, the plot should provide general information as outlined in 14.1. Electronic piezocone penetrometer soundings should provide an additional plot of porewater pressure kPa (or lb_f/in.², kg/cm², bar, or other

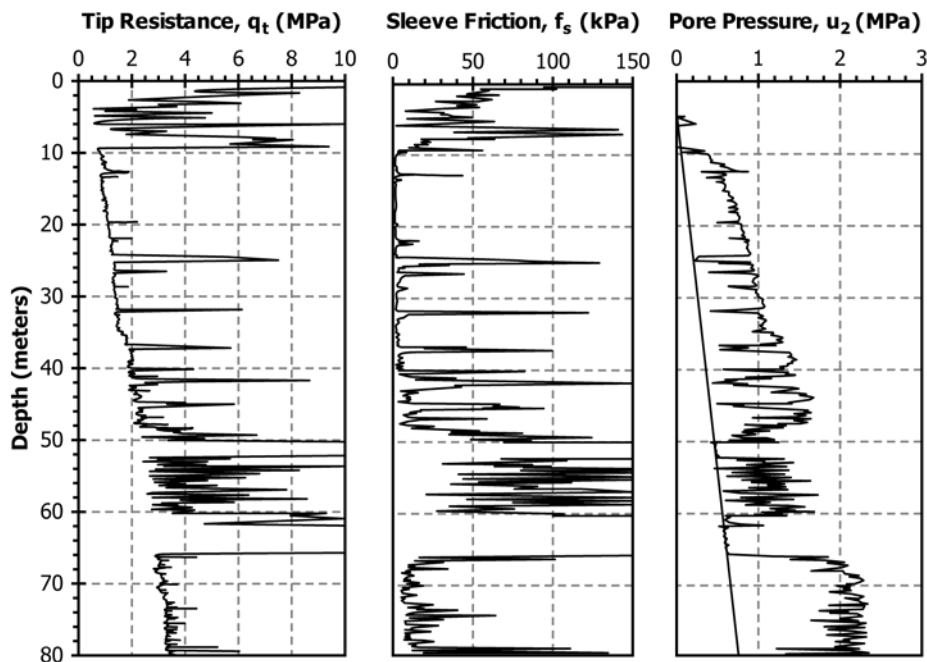

FIG. 4 Example Graph Presentation Results from a Conventional Piezocone Penetration Test

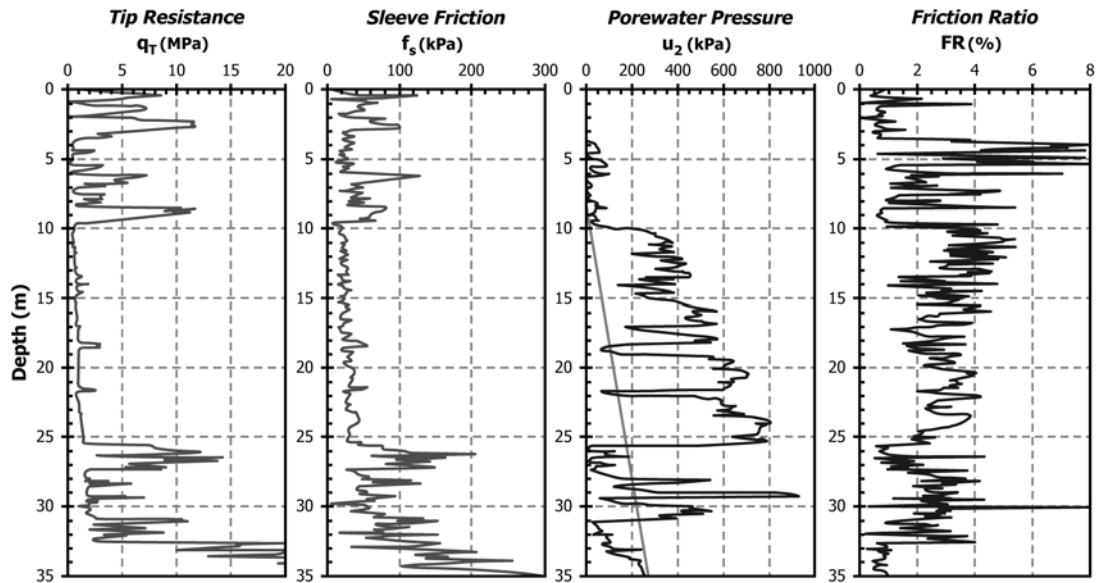

FIG. 5 Illustrative Piezocone Graph Showing Tip Resistance, Sleeve Friction, Penetration Porewater Pressure, and Friction Ratio

acceptable units of pressure) versus depth, m (ft). Porewater readings can be plotted as pressures, or alternatively, the pressure may be converted to equivalent heights of water (that is, $h_w = u_2/\gamma_w$).

14.4.1 Symbols q_t and f_s for tip and sleeve resistance are accepted by the International Society for Soil Mechanics and Geotechnical Engineering (4, 1, 5, 9).

14.4.2 For uniform presentation of data, the vertical axis (ordinate) should display depth and the horizontal axis (abscissa) should display the test values. There are many preferences in plotting such that uniform plotting scales and presentation will not be required.

15. Precision and Bias

15.1 Precision—There are little direct data on the precision of this test method, in particular because of the natural variability of the ground. Committee D-18 is actively seeking comparative studies. Judging from observed repeatability in approximate uniform deposits, persons familiar with this test estimate its precision as follows:

15.1.1 Cone Resistance—Provided that compensation is made for unequal area effects as described in 13.2.1, a standard deviation of approximately 2 % FSO (that is, comparable to the basic electromechanical combined accuracy, nonlinearity, and hysteresis).

15.1.2 Sleeve Friction—Subtraction Cones—Standard deviation of 15 % FSO.

15.1.3 Sleeve Friction—Independent Cones—Standard deviation of 5 % FSO.

15.1.4 Dynamic Porewater Pressure—Strongly dependent upon operational procedures and adequacy of saturation as described in 11.2. When carefully carried out a standard deviation of 2 % FSO can be obtained.

15.2 Bias—This test method has no bias because the values determined can be defined only in terms of this test method.

NOTE 13—Jefferies and Davies (14) report q_t repeatability of the two different soundings in compact clean sand using two different cones by the same manufacturer. Approximately 50 % of the data lay within 8 % of the average of the two tests, and 90 % of the data lay within 15 % of the average. In this trial the transducers (that conformed to the requirements in A1.5) were loaded to between one tenth and one fifth of their rated FSO, so confirming a standard deviation of better than 2 % FSO.

16. Keywords

16.1 cone penetration test; cone penetrometer; explorations; field test; friction resistance; geotechnical test; in-situ testing; penetration tests; penetrometer; piezocone; point resistance; porewater pressures; resistance; sleeve friction; soil investigations

(Mandatory Information)

A1. CALIBRATION REQUIREMENTS ON NEWLY MANUFACTURED OR REPAIRED ELECTRONIC FRICTION CONE AND PIEZOCONE PENETROMETERS

A1.1 Introduction:

A1.1.1 This annex describes procedures and requirements for calibrating electronic cone penetrometers. The evaluation of cone penetrometer calibration as described in this annex is a quality assurance standard for newly manufactured and repaired penetrometer tips. Many of the standards may be impractical to evaluate under field operating conditions. Therefore, determination of these calibration errors for any individual penetrometer tip should be performed in a laboratory environment under ideal conditions by the manufacturer or other qualified personnel with necessary knowledge, experience, and facilities.

A1.1.2 The electronic cone penetrometer is a delicate instrument subjected to severe field conditions. Proper use of such an instrument requires detailed calibration after manufacture and continuous field calibrations. Years of cone penetrometer design and performance experience have resulted in refined cone designs and calibration procedures which make the electronic cone penetrometer a highly reliable instrument. Reports of these experiences form the basis for requirements in this annex (3, 4, 1, 5, 11, 12).

A1.1.3 The required calibration tolerances developed in this annex are based on subtraction type electronic cone penetrometers. These penetrometers are more robust than electronic cone penetrometers with independent tip and sleeve load cells and are the most widely used design. The subtraction type penetrometer, however, has less precision due to the subtraction process (5, 11). As a result, calibration tolerances given here are considered maximum values and requirements for more sensitive cone penetrometers imply smaller tolerances having greater precision. The calibration process consists of loading the penetrometer tip with reference forces and pressures and then comparing measured output to the reference.

A1.1.4 Calibrations in the laboratory environment should be performed with the complete penetrometer system to be used in the field. The same make and model computer, cable, signal conditioning system, and penetrometer to be used in the field shall be calibrated in the laboratory. Depending on the components of the system some components may be substituted with acceptable replacements. Each individual penetrometer must be tested over a range of loads to assure adequate performance.

A1.2 Terms Related to Force Transducer Calibrations:

A1.2.1 Fig. A1.1 is a graphical depiction of terms related to transducer calibrations and defines the concepts of zero-load error, nonlinearity, hysteresis, and calibration error (3, 1, 10).

A1.2.2 To evaluate several of these values, the FSO (full scale output) of the penetrometer tip is needed. The manufacturer shall provide full scale output information for the system.

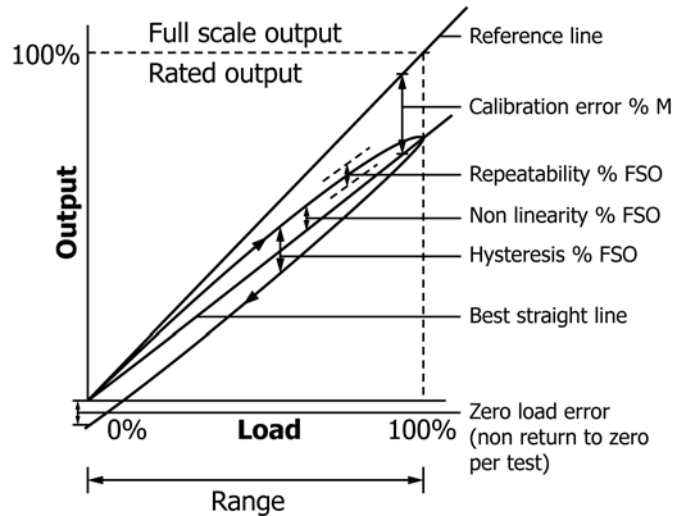

% FSO = percentage of full-scale output
 % M = percentage of measured output

FIG. A1.1 Definition of Calibration Terms for Load Cells and Transducers (1, 10)

Cone penetrometer tips usually are available in nominal capacities of 2, 5, 10, and 15 metric tons. Typical full-scale outputs for these penetrometer tip ranges as follows:

Nominal Capacity	Full-Scale Output of Cone, q_c		Full-Scale Output of Friction Sleeve, f_s	
	ton/ft ²	MPa	ton/ft ²	kPa
metric tons				
2	200	20	2	200
5	500	50	5	500
10	1000	100	10	1000
15	1000	100	10	1000

A1.2.3 It is important to check with the manufacturer on the full scale output of electronic cone penetrometer tips to avoid overloading and damaging penetrometer tips.

A1.3 Zero Load Baseline Values:

A1.3.1 Zero-load output variation of the cone penetrometer during testing and calibration is a reliable indicator of output stability, internal O-ring friction, and temperature-induced apparent load. The variation in zero load output is affected by temperature fluctuation because temperature compensated strain gages do not compensate for material effects and system component effects (3, 4, 1, 5, 10).

A1.3.2 Systems with microprocessors provide “reference baseline” values for the transducers that are not equal to zero but are measured positive or negative values depending on the electronics of the system. For the particular penetrometer and

penetrometer system used, the baseline values should remain relatively constant through the life of the penetrometer. As testing is performed in the field, the baseline resistances are monitored for changes. If large changes are noted the penetrometer should be loaded to check for linearity and possible damage. Evaluate the zero-load error during load range calibration by taking the difference between initial and final baseline values.

A1.3.3 Thermal Stability—For ensurance of thermal stability, evaluate a particular design of a newly manufactured cone under a range of temperature conditions. Newly manufactured penetrometer tips are first cycled to a minimum of 80 % of FSO five times at room temperature, to remove any residual nonlinearity. After cycling, establish an initial reference baseline value at room temperature after the cone has been electrically powered for about 30 min. To evaluate thermal stability, stabilize the penetrometer tip at temperatures of 10 and 30°C and new baseline values are obtained. The change in baseline values must be ≤ 1.0 % FSO of either cone or friction sleeve resistances.

A1.4 Load Range Calibration:

A1.4.1 Calibrate newly manufactured or repaired cone penetrometers over a range of loads after production or repair. Load test the cone penetrometer system in a universal testing machine or specially designed cone penetrometer calibration device capable of independently loading the cone and friction sleeve. If a universal testing machine is used, a calibration certificate (current within the last year) in accordance with Practice E4 must be available. If a cone calibration apparatus is used, it should also have a calibration document current within the last year. The calibration document shows that applied forces or masses are traceable to standard forces or masses retained by the National Institute of Standards and Technology. The universal testing machine or cone calibration devices must be capable of loading the penetrometer tip to 100 % FSO.

A1.4.2 Selection of loading steps and maximum loading varies depending on need and application. Select the load steps and maximum load to cover the range of interest and not necessarily the maximum capacity of the cone. Some calibrations stress more frequent load steps at lower loads to evaluate weaker materials. Selection of more frequent lower load steps may result in higher levels of calibration error since the best fit line is more influenced by the low range data.

A1.4.3 Perform the loading after the cone is subjected to five cycles of compressive loading and reference baselines, or internal zeroing, have been obtained at room temperature. The penetrometer is loaded in a minimum of six increments at forces equivalent to 0, 2, 5, 10, 25, 50, and 75 % FSO. At each increment of force, record both cone and sleeve resistances. Compute the actual cone tip resistance by dividing the applied force by the cone base area. The friction sleeve resistance is taken as the corresponding axial force over the sleeve area. Determine the “best fit straight line” by linear regression of applied force and measured output. The linearity is the difference between measured cone resistance and best-straight line cone resistance divided by the cone FSO. Evaluate hysteresis by comparing the difference between cone resistance at the

same level of applied force in loading and unloading and dividing by cone FSO. Calculate calibration error by taking the difference between the best-fit-straight line cone resistance and actual cone resistance and dividing by the actual cone resistance. Calibration error can become larger with smaller measured outputs and, therefore, it is not evaluated at loadings equivalent to less than 20 % of cone FSO.

A1.4.3.1 When calibrating the penetrometer, monitor the friction sleeve resistance to evaluate apparent load transfer. With a subtraction-type electronic cone penetrometer tip, the apparent friction sleeve resistance is caused by electrical subtraction error, crosstalk, and any load transferred mechanically to the sleeve. With a cone, that provides for independent cone and sleeve measurements, apparent friction sleeve resistances are caused by electrical crosstalk and mechanical load transfer. Apparent load transfer must be less than 1.5 % of FSO of the friction sleeve (1000 kPa).

A1.4.3.2 Maximum nonlinearity should be 0.2 %, maximum calibration error should be 0.5 %, and maximum apparent load transfer should be 1.2 %. For this calibration, the zero load error was zero. Hysteresis was not evaluated in this example because the testing machine was incapable of producing the exact same force on the loading and unloading steps.

A1.4.4 For calibration of the friction sleeve element, apply the forces in seven increments at 0, 2, 5, 10, 25, 50, and 75 % of FSO. Nonlinearity, hysteresis, and calibration error are evaluated in the same manner as calibrations for the cone tip reading. During friction sleeve calibration, monitor cone tip resistance to evaluate apparent load transfer that was not apparent in this calibration.

A1.5 Force Transducer Calibration Requirements:

A1.5.1 Calibration requirements developed for electronic cone penetrometers are based on past experience with subtraction-type electronic cone penetrometers and, as a result of this experience, represent the minimum precision requirement of electronic cone penetrometers. In cases where a higher level of precision is required, stricter calibration requirements would be required. Newly manufactured or repaired electronic cone penetrometers are required to meet the following requirements:

Calibration Parameter	Element	Requirement
Zero-load error	Tip and sleeve	$\leq \pm 0.5$ % FSO
Zero-load thermal stability	Cone tip and sleeve	$\leq \pm 1.0$ % FSO
Nonlinearity	Cone tip	$\leq \pm 0.5$ % FSO
	Sleeve	$\leq \pm 1.0$ % FSO
Hysteresis	Tip and sleeve	$\leq \pm 1.0$ % FSO
Calibration error	Cone tip	$\leq \pm 1.5$ % MO at >20 % FSO
	Sleeve	$\leq \pm 1.0$ % MO at >20 % FSO
Apparent load	While loading cone tip	$\leq \pm 1.5$ % FSO of sleeve transfer
	While loading sleeve	$\leq \pm 0.5$ % FSO of cone tip

A1.6 Pressure Transducer Calibrations:

A1.6.1 Newly manufactured or repaired pressure transducers shall be supplied with a load range calibration provided by the manufacturer. The load range calibration shall consist of a minimum of six points of loading to at least 75 % of FSO. The

applied pressures shall be traceable to reference forces maintained by NIST. The calibration shall meet the manufacturer’s stated tolerances. Minimum requirements are linearity better than 1 % of FSO and zero load error less than ± 7 kPa (± 1.0 lb/in.²).

A1.6.2 The transducer shall be subjected to regular periodic inspection meeting requirements in A1.6.1.

A1.7 Correction of Tip and Sleeve Areas:

A1.7.1 The conceptual regions where water pressures can act on the cone tip and sleeve elements are shown in Fig. A1.2. Water pressure that acts behind the cone tip will reduce measured cone resistance, q_c , by the magnitude of water pressure acting on unequal areas of the tip geometry. It is therefore advantageous to use a penetrometer having a net area ratio $a_n = 0.80$ in order to minimize the effect of the correction (4, 1). Water pressure may also act on both ends of the sleeve, resulting in an imbalance of forces if the sleeve is not designed with equal effective end areas. The water pressures acting on the ends of the sleeve are not just a function of geometry, they are also a function of the location of water seals. Water pressures during penetration are not often measured at both ends of the sleeve (that is, simultaneous u_2 and u_3) so a correction is not normally made for f_s (5).

A1.7.2 Equal end area friction sleeves should be required for use and should be designed by the manufacturer. The best method for evaluating sleeve imbalance is to seal the penetrometer in a pressure chamber and apply forces to measure the sleeve resistance after zeroing the system. Manufacturers should perform this check for a particular design to assure minimal imbalance.

A1.7.3 In order to calculate the corrected total cone resistance, q_t , as shown in 13.2.1, it will be necessary to determine the area ratio of the cone. The penetrometer can be enclosed in a sealed pressure vessel (for example, triaxial cell) and water pressures should be applied as shown in the example in Fig. A1.3. The net area ratio is then used in computing the corrected total tip resistance.

A1.8 Other Calibrations—Other sensors such as inclination, temperature, etc. may require calibration depending on the requirements of the investigation. Perform such calibrations using similar techniques given in this annex or by other reference procedures. Report such calibrations when required.

A1.9 Documentation of Calibrations:

A1.9.1 Laboratory calibration documents consisting of a short report on the equipment and methods of testing, along with tables and figures similar to those in this annex, are required for the following occurrences:

- A1.9.1.1 When new penetrometer tips are received, and
- A1.9.1.2 When damaged penetrometer tips are repaired.

A1.9.2 The report must be certified by a registered professional engineer or other responsible engineer with knowledge and experience in materials testing for quality assurance. Calibration documents are retained on file by the offices responsible for performing soundings and should be updated at required intervals. For contract soundings, calibration documents should be obtained prior to contract acceptance and after testing on unaltered equipment.

A1.9.3 If the electronic cone penetrometer meets the field calibration requirements given in 10.1.3, it is only necessary to

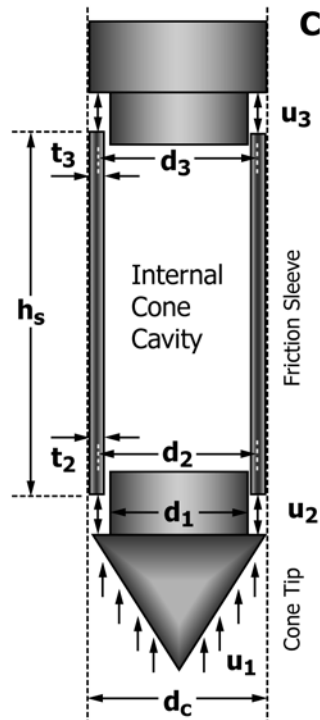

Corrections for Tip and Sleeve Readings

- d_j = diameter geometry (as shown)
- t_j = thickness of friction sleeve
- u_i = measured porewater pressure
- q_c = measured cone tip resistance
- f_s = measured sleeve friction
- q_t = total cone tip resistance
- f_t = total sleeve resistance
- a_n = tip net area ratio from triaxial test
- b_n = sleeve net ratio from triaxial test
- h_s = height of sleeve

Sleeve Friction:

$$f_t = f_s - (\pi d_2 t_2 u_2 + \pi d_3 t_3 u_3) / (\pi d_c h_s)$$

$$f_t \approx f_s - b_n u_2$$

Tip Resistance:

$$q_t = q_c + (1 - a_n) u_2$$

FIG. A1.2 Schematic of Net Area Ratio (a_n) for Corrections of Cone Tip Resistances (6)

Tip and Pore Pressure Calibration

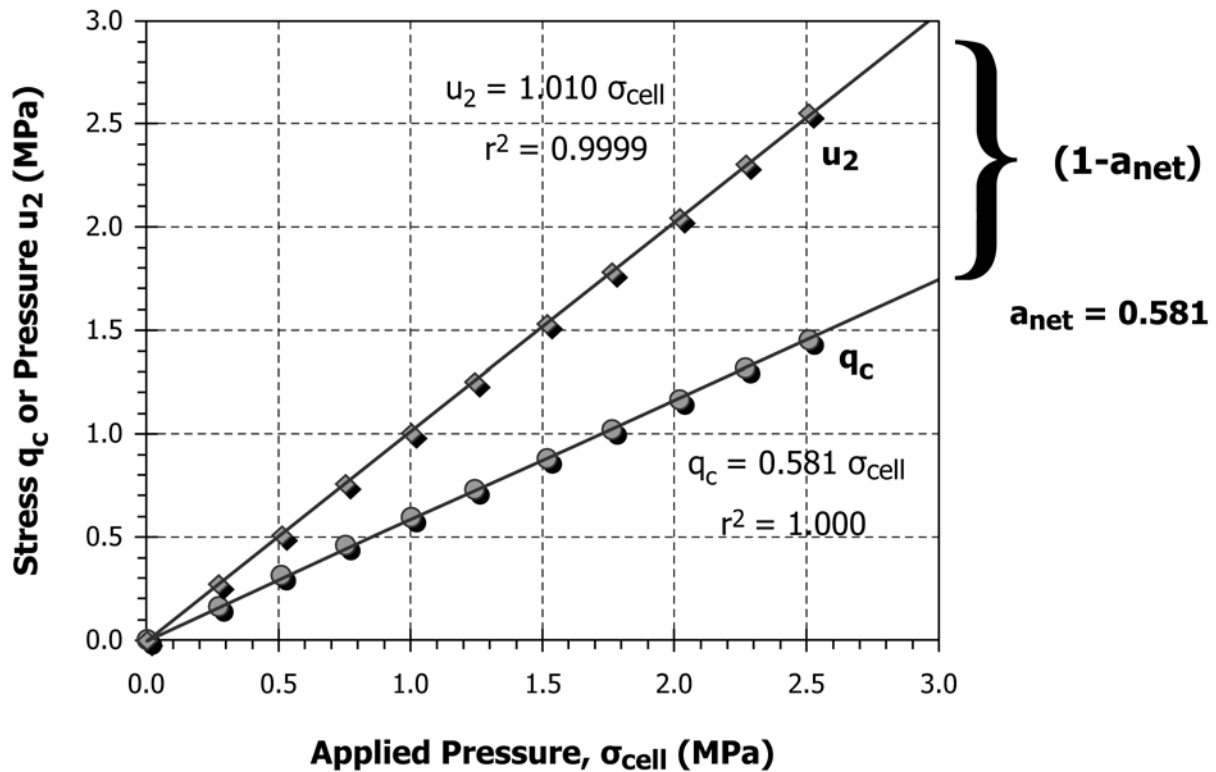

FIG. A1.3 Illustrative Example Determination of Unequal End Area for Correction of Tip Resistances Using Pressurized Triaxial Cell Calibration

adjust the penetrometer tip to the laboratory requirements on a yearly basis. Cone penetrometers should be calibrated using laboratory procedures prior to use on each new project, but

they do not need to meet calibration tolerances as required for newly manufactured cones.

REFERENCES

- (1) Lunne, T., Robertson, P.K. and Powell, J.J.M. (1997), *Cone Penetration Testing in Geotechnical Practice*, Blackie Academic/Routledge Publishing, New York, 312 pages.
- (2) Tumay, M.T., Boggess, R.L., Acar, Y. (1981). "Subsurface Investigation with Piezocone Penetrometer," ASCE GSP on Cone Penetration Testing and Experience, St Louis, MO., 325-342
- (3) Zuidberg, H.M., Schaap, L.H.J., and Beringen, F.L (1982). "A Penetrometer for Simultaneously Measuring of Cone Resistance, Sleeve Friction and Dynamic Pore Pressure," *Proceedings of the Second European Symposium on Penetration Testing*, Vol. 2, Amsterdam, 963-970
- (4) Campanella, R. G., and Robertson, P. K. (1988), "Current status of the piezocone test," *Penetration Testing 1988* (Proceedings, ISOPT-1, Orlando), Vol. 1, Balkema, Rotterdam, 93-116.
- (5) *International Reference Standard for the Cone Penetration Test* (1999), Technical Committee TC 16, ISSMGE, Proceedings, 121th European Conf. on Soil Mechanics & Geotechnical Engineering (Copenhagen), Vol. 3, Balkema, Rotterdam, 2195-2222.
- (6) Jamiolkowski, M., Ladd, C.C., Germaine, J.T. and Lancelotta, R. (1985), "New developments in field and lab testing of soils," *Proceedings, 11th International Conference on Soil Mechanics & Foundation Engineering*, Vol. 1, San Francisco, 57-154.
- (7) Mayne, P.W. (2007), *Synthesis 368 on Cone Penetration Testing*, NCHRP 20-05 (Task 37-14), National Academy Press, Washington, D.C., 162 p.
- (8) Mulabdić, M., Eskilson, S., and Larsson, R. (1990), "Calibration of piezocones for investigations in soft soils and demands for accuracy of the equipment," *SGI Varia* No. 270, Swedish Geotechnical Institute, Linköping, 62 p.
- (9) DeBeer, E.E., Goelen, E., Heynen, W.J. and Joustra, K. (1988). "Cone penetration test: International reference test procedure," *Penetration Testing 1988*, (Proceedings, ISOPT-1, Orlando), Vol. 1, Balkema, Rotterdam, 27-52.
- (10) Schaap, L. H. J., and Zuidberg, H. M. (1982), "Mechanical and electrical aspects of the electric cone penetrometer tip," *Proceedings of the Second European Symposium on Penetration Testing*, Vol. 2, Amsterdam, 841-851.
- (11) DeJong, J.T, Yafrate, N.J., and DeGroot, D.J. (2007), "Design of a miniature piezoprobe for high resolution stratigraphic profiling," *ASTM Geotechnical Testing Journal*, Vol. 30 (4), 11 p.

- (12) De Ruiter, J. (1982). “The Static Cone Penetration Test: State-of-the-Art Report,” *Proceedings of the Second European Symposium on Penetration Testing*, Vol. 2, Amsterdam, 389-405.
- (13) Lutenegeger, A.J. and DeGroot, D.J. (1995), “Techniques for sealing cone penetrometer holes,” *Canadian Geotechnical Journal*, Vol. 32 (5), 880–891.
- (14) Jefferies, M. G., and Davies, M. P. (1993), “Use of the CPTu to Estimate Equivalent SPT N60,” *Geotechnical Testing Journal*, Vol. 16, No. 4, ASTM, 458–468.

SUMMARY OF CHANGES

Committee D18 has identified the location of selected changes to this test method since the last issue, D5778–07 that may impact the use of test method. (Approved January 1, 2012)

- (1) Added reference to Test Methods **D7400**.
- (2) Clarification of definition **3.2.10** *electronic piezocone penetrometer*.
- (3) Added new references and corrected reference numbers in text for these changes.
- (4) Corrected **Eq 8**.
- (5) Corrected definition of symbols used in **Eq 7**, **Eq 8**, and **Eq 9**.
- (6) Added **Note 2** and **Note 3** and renumbered subsequent notes.
- (7) Added reference to **Note 2** in **13.4**.
- (8) Deleted terms *hydrostatic pressure*, *hydrostatic porewater pressure*, and reference to Terminology **D653** in **3.2.10** and **13.5.3**.

ASTM International takes no position respecting the validity of any patent rights asserted in connection with any item mentioned in this standard. Users of this standard are expressly advised that determination of the validity of any such patent rights, and the risk of infringement of such rights, are entirely their own responsibility.

This standard is subject to revision at any time by the responsible technical committee and must be reviewed every five years and if not revised, either reapproved or withdrawn. Your comments are invited either for revision of this standard or for additional standards and should be addressed to ASTM International Headquarters. Your comments will receive careful consideration at a meeting of the responsible technical committee, which you may attend. If you feel that your comments have not received a fair hearing you should make your views known to the ASTM Committee on Standards, at the address shown below.

This standard is copyrighted by ASTM International, 100 Barr Harbor Drive, PO Box C700, West Conshohocken, PA 19428-2959, United States. Individual reprints (single or multiple copies) of this standard may be obtained by contacting ASTM at the above address or at 610-832-9585 (phone), 610-832-9555 (fax), or service@astm.org (e-mail); or through the ASTM website (www.astm.org). Permission rights to photocopy the standard may also be secured from the Copyright Clearance Center, 222 Rosewood Drive, Danvers, MA 01923, Tel: (978) 646-2600; <http://www.copyright.com/>